



**European Commission
'Intelligent Energy – Europe'
programme**

**Energy Savings from Intelligent Metering and
Behavioural Change**

Contract N°: EIE/04/107/SO7.38635

Monitoring Specification (Deliverable 2)

**Work Package 1: Monitoring Specification
Work Package Leader: Energieagentur Waldviertel**

Date:.....July 7th, 2005.....

Table of contents

1. Summary	2
2. Introduction	3
3. Definition of inputs and outputs required from system	3
4. Specification for the Intelligent Metering system.....	4
4.1 In general:.....	4
4.2 Meters:.....	4
4.2.1 Electric meter:.....	4
4.2.2 Natural-gas-counters:.....	7
4.2.3 Heat meters:.....	8
4.2.4 Water meters:.....	9
4.3 Transmission of the impulses and data from the meter to the data-logger:	10
4.3.1 Types of data transmissions:.....	11
4.4 Data-logger:.....	12
4.5 Structure of data flow in intelligent metering.....	13
4.6 Metering data set of buildings	14
4.7 The data structure of the Esbensen data base:	16
4.8 Heat degree correction:.....	20
5. Conclusions	23

1. Summary

The accounting scopes chosen for the project intelligent metering are heating, electricity and water consumption. The outside temperature will be handled like an own accounting scope, this has its reason as a need of the dynamat analyzing program.

The building-analysis has to be carried out in the way so that the consumption-counters can be assigned to the sectors of usage of the buildings.

For the project the energy demand is determined, if this isn't possible, the next energy-conversion (e.g. heat at the main pipe of the central-heating boiler).

If possible one counter per accounting scope is enough. But if in sectors there are unusual uses, which don't come up to the category of the building, it's useful to equip these sectors with sub-counters.

It's profitable to readout existing counters or reconfigure them, so that they are suitable for the project Intelligent Metering. The advantage is not only a financial one, but also easier to realise technical.

Primarily all counters have to have at least impulse-outputs. The conversion into counter measurands is carried out via calculating-algorithms. The conversion can be carried out in the meter, in the data-logger or via software.

The sensors produce pulses; the users want to see values for their consumption assessments. Therefore there must be a conversion of pulses into values with a certain factor. This conversion can take place on different places. Each device following after this conversion may use an internal conversion factor of "1" to work with the values.

As there is a lot of data flow in this system of monitoring, it makes sense to use a time table for the sending and working processes. This will reduce traffic peaks on the Esbensen server.

Half hourly metering data will be sent to the Esbensen server. The Server sends once a day the metering data forward to the Leicester energy agency server, where the data are imported into the dynamat program. The CSV-file consists of 6 data fields per data set. The first 4 data fields are defined in format and content. The last 2 data fields could be used for maximum load and for the conversion factor of the counter. The results of the assessments will be sent to the Esbensen website. Building occupants and project partners can view these results.

The structure of the database is of high importance for the successful project. The dependencies of the data fields and the different writing rights of the different users are some key points.

2. Introduction

Please read the first delivery of monitoring needs for introduction. For the realization of the project some questions arise. This part should help to understand the problems and give suggestions for the conversion of the project intelligent metering.

3. Definition of inputs and outputs required from system

Inputs required:

Per object:

- additive counter for heating scope
- additive counter for electricity scope
- additive counter for water scope

sending pulses, somewhere in the intelligent metering system these pulses have to be translated into values

- value counter for outside temperature

delivers a voltage, which has to be transformed into values

Half hourly data will be metered, collected in a buffering device and sent to the Esbensen database. An important aspect for the server will be to reduce peaks in traffic of the data communication. Therefore a time plan will be helpful.

activity	interval	location	comment	time gap (e.g.)
auto sending	once a day each	from building to Esbensen database	each partner has an own time gap	0:00 to 5:00
auto sending	once a day each	from Esbensen database to LEA-Server	csv-file, auto import into dynamat	5:00 to 6:00
auto evaluation	once a day each	at LEA-Server	at least last few days and few weeks	6:00 to 7:00
auto sending	once a day each	from LEA-Server to Esbensen database	results as pictures or/and tables	7:00 to 8:00
auto update	once a day each	at Esbensen website		8:00 to 8:30

Outputs delivered:

- Consumption results for the different accounting scopes on the Esbensen website updated once a day
- Esbensen database for identifying abnormal consumption and its causes
- Esbensen database for identifying of best practice examples
- Esbensen database for evaluation of the project itself

- Trained building occupants
- Trained trainers (e.g. caretakers of buildings)

4. Specification for the Intelligent Metering system

4.1 In general:

For this project it's essential to analyse the buildings very precisely. The more precisely the buildings are analysed, the better the evaluation will be. Already at the stage of the analysis of the buildings, possible weak spots concerning usage, control systems, equipment set-up, and so on can be determined. The person who is responsible for the building, who is taught in line with the project, should be asked after the weekly activity of the usage. Furthermore eventual special-uses, e.g. unusual arrangements have to be determined. It's essential to determine which meters are assigned to which sector of the building. This is interesting at different uses. For instance a school kitchen in a full-time-school, an office building with museum-service, a school with habitations and so on.

Should there are such special-uses in a building, it's helpful to install sub counters to determine the consumption. By splitting up the consumption-sectors, it's easier to time the development of the consumption. At minimum there is one counter per each accounting scope necessary.

At the determination of the heating-energy-demand following guidelines were set up:

1. Generally the end-energy should be determined. (natural gas, heat,)
2. If it's difficult to determine the end-energy, the heating energy after the central-heating boiler should be determined.
3. At energy carrier natural gas the m³ natural gas have to be determined.
At heating oil the kWh heat after the central-heating boiler have to be determined.
At electricity the kWh from the counter have to be determined.

4.2 Meters:

The consumption-counters have to be determined at the enquiries, to notice which consumption-counters are able to be adapted for automatic remote-monitoring.

4.2.1 Electric meter:

In general there are two sorts of counters. Analogue counters and digital counters.
For the calculation of the electrical work, the general formula applies for all counter-systems:

$$Q = I * U * t * \cos \varphi = [\text{kWh}]$$

Q	electrical active energy [kWh]
I	current [A]
U	voltage [V]
cos φ	cosine phi (rating factor)
t	time

Analogue electric meters:

These are still widely spread, are very robust and are easily to read off. The disadvantage is that these counters are not suitable for remote-metering. For this reason these counters have to be replaced with digital- meters.

Types of analogue counters:

Electrical work at low power up to 26 kW:

Ferraris counter

Electrical work at high power:

Ferraris counter with current transformer,

The current transformers transform high currents into lower currents, which are easier to measure. This is expressed in a ratio such as 1:50, which means that the result of the measurement has to be multiplied with a factor of 50. (Consumption value 10kWh of the counter is actually 500kWh)

Digital counters:

In general:

At the energy-supply-companies there are different equipments of counters. Due to different meter-structures, like impulse frequencies (sampling instance) and so on, it leads to different numeric counting results. These have to be converted by a calculating algorithm in the counter or the data-logger. For instance there are 3000 impulses per kWh by electrical meters.

Example: 600.000 impulses.

$$Q = [600.000 \text{ Imp}] : 3000 [\text{Imp.} / \text{kWh}] = 200 \text{ kWh}$$

The impulse algorithm differs from manufacturer to manufacturer, and so the adjustments have to be done by the data-logger or via software.

A further development is the M – Bus counter, which don't display the impulses to measure the data, but counter reading. This data no longer has to be calculated in combination with a calculating algorithm, but is able to be led directly to the corresponding database.

Determination of the electrical work (counter I = 10 to 60 A) Four conductor counter:

Option A:

Counters of the energy-supply-company are used to read out the data:

(see appendix 2, picture 1)

If there are still analogue work-meters present in the installation, it's profitable to replace them with digital counters. It's essential to receive an **impulse signal**. Another important point is to coordinate the work with the network operator, because the allocation counter belongs to this company and for this reason a manipulation on it is not allowed. To enable the read off with the counter of the network operator, it's essential to physically separate both counter-systems. A separation is necessary, to avoid the transmission of interferences. For instance a short circuit on external meters could damage the counter-installation or could influence the result of the measurement. Remedy is achieved by a decouple-relay or an optocoupler

(see Figure 1). The advantages of this option are that there is only one result of the measurement, and that the consumption data is equal to the measuring data of the energy-supply-company.

At some energy-supply-companies it's common to account different tariffs. The counters are able to gather multiple consumption-tariffs. For instance, by day (06.00 – 22.00) a higher tariff is accounted and by night (22.00 - 06.00) a lower one. This is due to the fact that there is more electricity needed by day, and it's more difficult and more expensive to cover the energy-peaks.

For the project Intelligent Metering it's not necessary to record the electrical energy consumption by tariffs, because there are firstly different tariff-models in the member countries, and secondly only the energy-consumption of the building is crucial.

In bigger objects it's absolutely common to determine and to account the reactive energy [kVArh]. In the project Intelligent Metering only the active energy is determined.

If there are multi-tariff-counters (active energy kWh) in the objects, there are two possibilities to determine the energy-consumption without the influence of accounting modalities.

1. The counter impulses are displayed always the same, whatever tariff is used. The impulses are switched to the particular tariff-counter via a switch (Mp). To receive consumption-impulses it's necessary to set up a connection between the tariff-impulses (connection tariff 1 and tariff 2). In result of this measure we get a counter which is independent of diverse tariff-constellations.
2. The counter impulses are counted separately and are added together with software. This could happen in connection with energy-accounting software. In energy-accounting-systems, further it is essential to know which consumption is assigned to which tariff, because only then a satisfying allocation of costs is able to happen.
The separated tariffs are added together and are combined to a virtual counter.

Option B:

Counters of the energy-supply-company are not used for the readout of the data:

In general: Counters of the energy-supply-company are not used for the readout of the data if there isn't the possibility to use the existing counter-installation, or if there are no separate counters for different fields of use. Often also the energy-supply-companies are not interested in adapting the counter-installation to allow remote-read-out.

Then only parallel installed remote-readout-counter-installations can be used. It must be pointed out that the power supply has to be disconnected, to allow the installation of the remote-read-out-counters.

It's essential that these counters are impulse-counters.

Electrical work at high power (counter I > 60 A):

At the work-counters for higher power the energy is not measured directly, but via counter-converters. Cause is the high currents which are difficult to measure directly. At low voltages (400 V~) predominantly current-converters are used. Current-converters are able to convert high currents into low currents which are easily to measure. The functionality is based on the transformer-principle. The reduced measured current is consulted for the consumption-measurement. The real energy-consumption is much higher than the measured value. This difference is quoted by a counter-multiplier. For instance counter-multiplier 30, 300kWh metered.

$$Q_{\text{real.}} = 30 * 300 \text{ [kWh]} = 9.000 \text{ kWh}$$

The counter just displays the value; afterwards the actual consumption-value has to be calculated. The energy-supply-companies calculate this on their billing.

In the project Intelligent Metering this is able to happen automatically. As at the four conductor counters the energy demand is displayed via predetermined impulses. With help of the calculating-algorithm the counter-multiplier can be set to determine the energy demand.

Option 1:

Counters of the energy-supply-company are used to read-out the data:

(see appendix 3, picture 2)

Basically, the same as with the four conductor counters in option A is true for.

Option 2:

Counters of the energy-supply-company are **not** used to read-out the data:

In most cases option A is the one which is easier to realise and more favourable. If the readout of the existing counters isn't able, new counters have to be installed parallel. This also includes the installation of current-converters and the corresponding wires and connectors. Furthermore it's necessary to disconnect the power supply to install the current-converters on the bus bar.

It's essential that these counters are impulse-counters.

4.2.2 Natural-gas-counters:

Analog counters

At natural-gas-counters, four chambers are filled with gas periodically. The content is registered and the gas is led to the exit (bellows-type gas flow meter).

So that the chambers, which are furnished with a membrane, are able to swing and are able to fulfill their meter-function at this little pressure, relatively big chamber-surfaces are necessary. ($F = p \times A$)

Functionality of a bellow-type gas flow meter:

The four chambers are filled alternately with gas, with this movement of the chambers the ordered gas is registered and the value is transmitted to the counter.

Phase 1:

Chamber 1 is empty Chamber 2 is filling

Chamber 3 drains Chamber 4 is full

Phase 2:

Chamber 1 is filling Chamber 2 is empty

Chamber 3 is full Chamber 4 drains

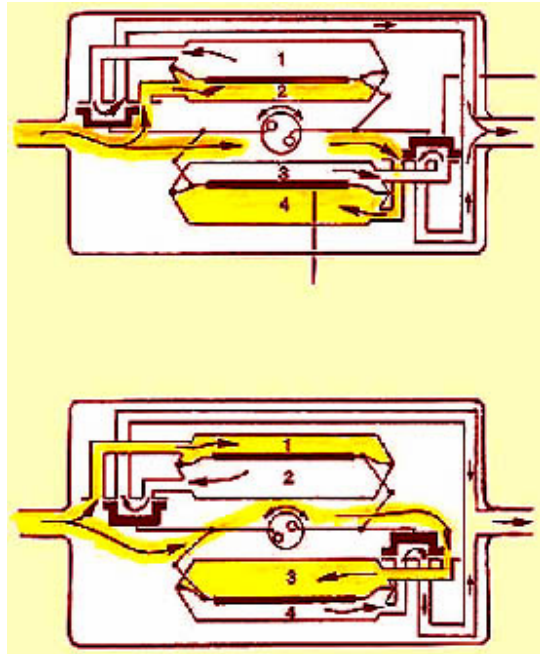

The energy-supply-companies often use calibrated mechanic accounting-counters. As they are mechanical counters, they have to be recalibrated at intervals of a few years. Mechanical natural gas-counters have to be equipped with a pulse generator to allow the automatic readout of the meter data. Impulses per m³ natural gas can differ at different counters. For this reason, the impulses have to be determined via a calculating-algorithm. Furthermore the natural-gas-constellation in different countries is also different, because the natural gas comes from different sources. This should also be taken into account at the conversion of the energy-demand into kWh.

Gas-counters for higher pressure are similar to the function of water-counters. The pressurized gas runs a turbine, which registers the revolutions in the meter.

Digital counters

Are not spread widely yet. There are several techniques to determine the energy demand. For instance with silicon technology:

The metering principle is already known for longer: a heating element with temperature sensors on both sides. At passive state both sensors deliver the same value. Is air or a gas flowing over this arrangement, the temperature spreading becomes asymmetric. Both sensors then deliver different signals, which are analyzed by the electronics.

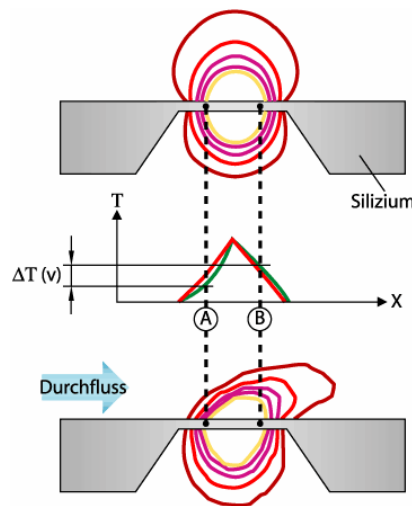

4.2.3 Heat meters:

Nowadays there are two widespread systems: heat meters with a mechanical wheel and ultrasonic-meters.

At heat meters the litres of warm water are counted via impulses (e.g. 12,6 pulses per litre). In combination with the temperature-difference Δ in Kelvin, the heat flow volume is determined.

$$Q = m * c * \Delta t$$

Q energy content [kWh]
 c specific heat capacity of water
 Δt temperature difference of the flow and return pipe

Generally the energy supply is realised via batteries. The operation period of the energy supply is about 5-8 years. At these systems it's essential to carry out periodic services and calibrations. So the batteries also are changed.

Heat meters with a mechanic wheel:

The wheel is based on an impeller. The amount of water, which flows through, operates an impeller. Its revolution speed is sampled electromagnetic without magnetic influence. The single-jet meter operates on the single-jet meter principle. The water flow, flows against the impeller tangential. The measuring capsule meter operates on the measuring-jet principle. The temperatures in the flow and in the return pipe are measured with platinum-measure-elements.

In most cases measuring capsule meters with impulse gates are mounted. If this isn't the event, the meters have to be changed.

Registration of the heat flow volume via ultrasonic:

Ultrasonic – heat meters determine the flow rate via the delay of sound waves. Short acoustic impulses with a sound frequency of 1MHz are sent with and against the flow direction of the heating medium through a measure tube. The pulses are generated by piezo-electric ultrasonic-converters (transmitter and receiver for ultrasonic). Due to the ultrasonic-entrainment-principle the delay t_{up} and t_{down} of the ultrasonic-sound waves is different. The delay-difference $\Delta t = t_{up} - t_{down}$ of the signals, which is formed in the calculator of the heat meter, is proportional to the average flow speed in the measure tube and so it's proportional to the volume of the heating medium.

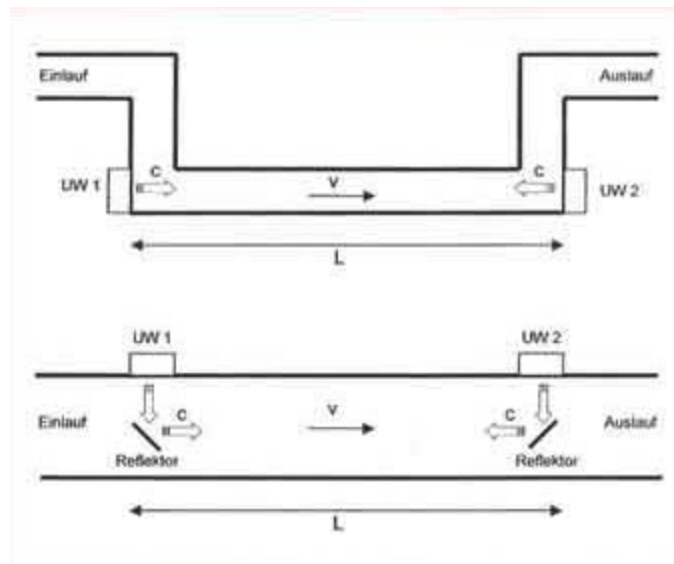

4.2.4 Water meters:

Water demand is measured via a wheel with a standardised pressure. [m³]

There are three wide-spread systems: water meters with a mechanical wheel, ultrasonic-meters and induction-meters.

Mechanic water counters:

The water enters the meter through the lower openings which are situated on the impeller, operates the impeller and leaves the enclosure through the upper openings.

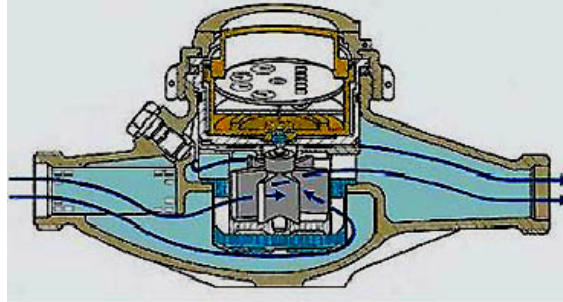

The energy of the impeller acts on the roll-counting train.

Optional in such mechanical meters there are reed-impulse-generators built in, which emit defined consumption-impulses.

The disadvantage of a mechanical solution is lime-accumulations on the impeller, which can lead to measurement inaccuracies. Therefore recalibrations are necessary in given intervals.

Registration of the water amount via ultrasonic:

This is primarily carried out as at the ultrasonic-heat-flow-volume-meters without the influence of the temperature.

Registration of the water amount via induction:

The registration happens via electromagnetic-induction. This kind of consumption-registration is maintenance-free as there are no mechanical parts used for the count.

4.3 Transmission of the impulses and data from the meter to the data-logger:

Primarily the data transmission is able to be carried out via radio or via copper-cables.

Data transmission via radio:

These systems are spread widely and offer a cost-saving alternative to the data transmission via wiring. This system consists of a transmitter and a receiver. These devices are operated via solar or via batteries. The transmission is carried out via radio waves, the range is ca. 1,5km to 15km. Due to this flexibility, this system can be used in specific buildings as well as in bigger building-complexes.

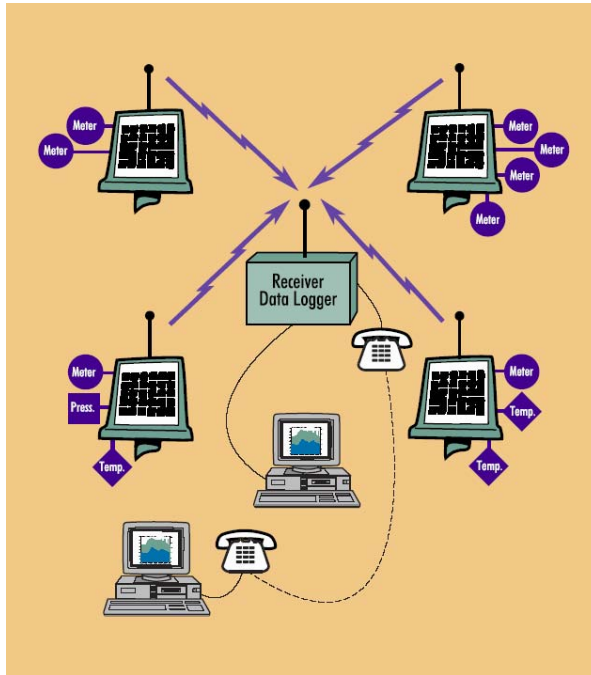

Data transmission via copper-cables:

This possibility represents one of the most used data transmission. At the stage of laying the cables, it's essential to pay attention that no interferences from the outside, which could disturb the signals in the cables, are present (induction-voltages, electrostatic fields, ...). This is avoided by shielding the cables and a separate lying of the data-cables.

A further problem is the limited cable-lengths which can differ according to the transmission method and the dimensioning of the cables.

The advantages are the sophisticated wiring-techniques and the cheaper cost price.

4.3.1 Types of data transmissions:

Data transmission via impulses:

Impulse-signals are easy to realise and are standard at the offered remote-read-out counters. The impulses are transmitted from the meter to the data-logger, where they are converted in meter readings via a calculating-algorithm. The counter-pulses are binary signals (0,1). The timing is set up accordingly to the consumption-demand. The pulse-generating could happen via a switch (mechanical), light-barrier (optical), or via approximation-induction (electrical). The length of the data-transmission-line is 1,5m at maximum. If bigger distances have to be overcome, repeaters have to be integrated.

Data transmission via S 0 signal-input:

A S 0 signal-input is a potential-free contact. The signal-voltage is provided from the data-logger external. The timing happens via the counter and the clocked signal is processed in the data-logger. The line lengths are limited to about 100 m.

Data transmission M – Bus (Meter Bus):

There no longer impulses, but counted measurands are used. The counters convert impulse-values into counted measurands, and transmit them to the data-logger. Up to 250 end devices can be attached to each channel. The maximum line lengths depend on the supplier and can be from 100m to 400m. Requirements are counters with an M – Bus output.

Der BusSwitcher ermöglicht eine einfache Erweiterung des M-Bus Netzwerkes

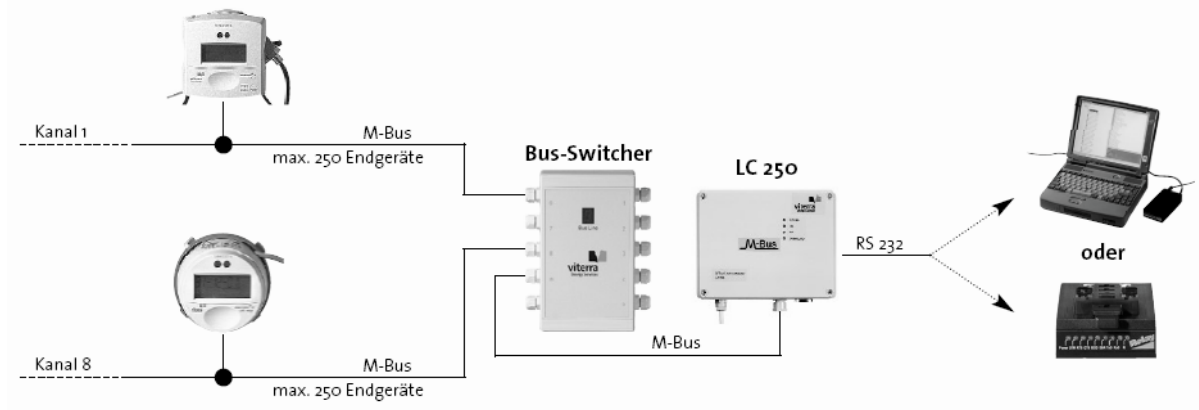

Outside temperature determination:

In the project Intelligent Metering the outside temperature is determined, for the temperature-correction. The temperature-correction serves to compensate the climatic differences. That means that the building easily can be compared with other buildings in the same category, no matter where it is located. (e.g. elementary school in Germany, England, Denmark).

4.4 Data-logger:

The data-logger collects and saves the consumption-data of various parameters, like temperature, pressure, counted measurands and so on. Thence the data is forwarded to a PC, LAN, HUP, Modem / GSM – Box.

Intelligent Metering - diagram data flow

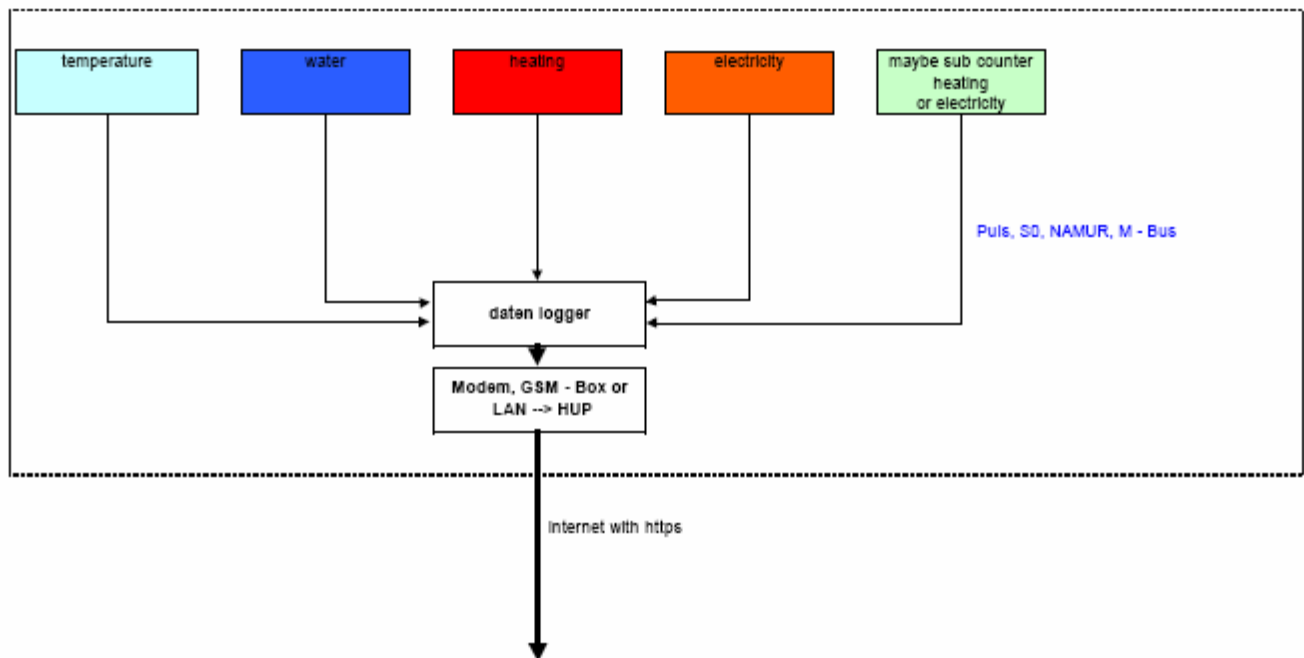

4.5 Structure of data flow in intelligent metering

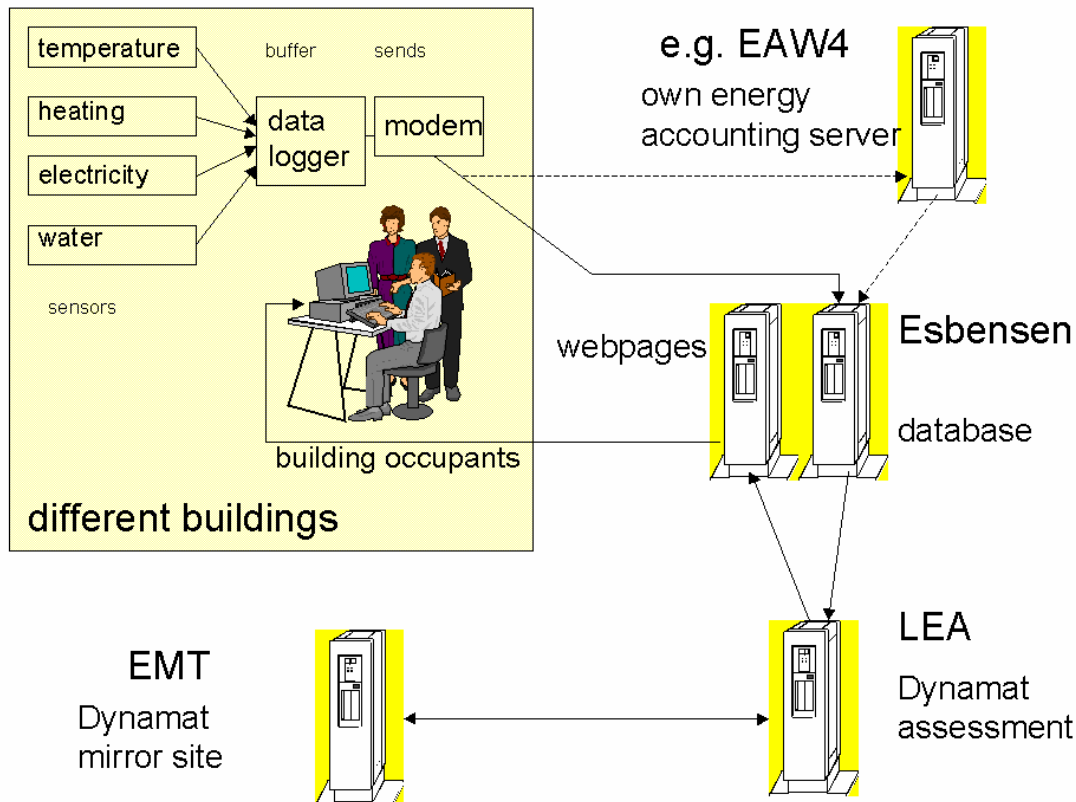

The sensors of the metering units send their pulses to a data logger every 30 minutes. The internal buffer collects them. Every 24 hours he activates the modem to send the data to the database. The translation from pulses into values can be done in the data logger, in the inserted energy accounting server (if there is one), in the Esbensen database or the dynamat evaluation program. The heating, electricity and water counter send pulses, if the right counter is used. The temperature sends normally a voltage that can be translated in data loggers with an analogue input into values. If possible Esbensen wants to receive values and not pulses for their database.

If the data are already values and have to be interpreted by another program, that normally reads raw data (=pulses) like EMT's Dynamat, they only have to use a conversion factor of „1“.

The modem may send the data directly to the Esbensen database, but an own energy accounting program may be inserted. This program has to forward the metering data to the Esbensen database. The metering data sets must have a fixed structure as written below.

The new metered data are forwarded from the database to the server of the Leicester Energy Agency (LEA), where the analyzing program Dynamat is installed. A mirror site exists in the internet; this is the one of Energy Metering Technologies Ltd (EMT). Each building consumption of every accounting scope is evaluated once a day. The results will be sent to the Esbensen Server, where the result-pictures are placed on the website of Esbensen and automatically updated daily. The building occupants can view their consumption on the website authorized by login and password.

The sensor of the metering unit sends out pulses. The results of the assessments are always values. The conversion of pulses into values may happen on different places. Different partners or even different buildings of one partner may have a different place for this translation.

pulses						values
sensor	counter	data logger	inserted database	Esbensen database	EMT dynamat	assessment

Example of possible places, where the conversion of pulses into values can be executed.

pulses			conversion			values
sensor	counter	data logger	inserted database	Esbensen database	EMT dynamat	assessment

Example where the energy agency Waldviertel will probably translate pulses into values (in the inserted database from Siemens emc for energy accounting).

pulses				conversion		values
sensor	counter	data logger	inserted database	EMT dynamat	Esbensen database	assessment

Example where the Leicester energy agency translate pulses into values at the moment.

Esbensen wants that all partners send values. So Leicester has to do some alteration from their existing system. Energy Metering Technology has given some more details about providing a CSV file with REAL values for Leicester rather than pulses. There is a function in DYNAMAT which produces the consumption data as half hourly consumption values (in kWh from pulses). This data is set out in 48 columns ('wide format'). As this is currently a manual process some work would be required to automate it.

Dependent from the language, there may be different data field separators like ";" or "," which may cause troubles (Energie 2000). Then a small (vba) script can be written to translate the separator. The script may work on different places (eg. data logger or inserted database or Esbensen database or dynamat software).

4.6 Metering data set of buildings

Common: meter-ID, date, time, value, load, consumption factor

For the single accounting scopes:

Heating: "METER CODE","dd/mm/yy","hh:mm:ss",99999.999,0,999999.99

Electricity: "METER CODE","dd/mm/yy","hh:mm:ss",99999.999,99999.999,999999.99

Water: "METER CODE","dd/mm/yy","hh:mm:ss",99999.999,0,999999.99

Temperature: "METER CODE","dd/mm/yy","hh:mm:ss",99999.999,0,0

We need this format to import the Data into the DYNAMAT program.

DYNAMAT's standard import format is a simple ASCII Comma Separated Value (CSV) format. Files can have any valid DOS filename, and must have the extension ".TXT". DYNAMAT uses a standard Windows "file open" box to import the files, so they can be placed anywhere on the hard disk but are most conveniently placed in the DYNAMAT program directory.

Each line consists of up to six values separated by commas, and is terminated by a carriage return:-

The items in each line are as follows:-

Meter code: This is a character string of up to 12 characters enclosed in quotes, which must correspond to "Your Meter Code" as entered in DYNAMAT's meter setup screen.

Date of reading: The date is a character string which must be in English format i.e. "dd/mm/yy". All eight characters must be present. For days or months which can be represented by a single digit, the digit must be preceded by a zero or space, e.g. "09/09/93" not "9/9/93". Internal delimiters other than the slash are acceptable, but the digits must appear in the correct position.

Time of reading: The time is a character string of the form "hh:mm:ss". Internal delimiters other than the colon are acceptable, but the digits must appear in the correct position. For readings which are not time stamped, i.e. invoices or manual meter readings, the time "13:00:00" should be used.

Reading: The reading is a number of any magnitude from 0.00001 to 9 999 999 999. The number of digits and decimal format are defined in DYNAMAT's setup screen. No units should be appended to the reading because they are also defined within DYNAMAT.

DYNAMAT can be set up to accept either an integrator value which is continually accumulating, or an amount consumed since the last time the meter was read. However, we recommend that wherever possible an integrator value is used, because this enables a correct total to be calculated even if some readings are missing.

We have to take care, that in Middle Europe the comma of decimal figures is used, whereas in Great Britain they use a point.

Additional information (field 5): This field is used for the "additional information" column on DYNAMAT's data entry screens. It is a number of any magnitude between 0.00001 and 9 999 999 999. The use of this field varies with the service type:-

Electricity: Maximum demand

It is acceptable to enter zero for this field if the data is not available (e.g. if the accounting scope is not electricity). To monitor the maximum load can be done by the partners, but it is not really necessary. You simply can divide the consumption through the time period to find out the load mathematically, as we use short intervals it is near the billed maximum demand.

These last two fields can be omitted.

Additional information (field 6):

Correction factor (1.00 if corrected meter readings or calculated kWh values are used). The energy carrier or/and counter factor may influence this value. This is a number up to 9,999,999.99. Do not include the unit.

Examples for this factor:

- a) the counter counts the Volume (m³) of the delivered natural gas. As 1 m³ of natural gas has a net caloric value of 9,5 kWh we use the correction factor 9,50.
- b) the electricity counter counts 1 each 120 kWh, the counter factor is 120. So the value 6 means 720 kWh. We use the correction factor 120,00.

4.7 The data structure of the Esbensen data base:

The data structure is a very important aspect for the intelligent metering project. There are two groups of data for the Esbensen database. The first one consists of the measuring data, which are collected, transmitted and imported to the database in an automated way. This data also have to be exported to the dynamat program automatically once a day for analyses.

The second group is additional data. This additional data helps to build a structure, gives a description of the object, may allow a conversion from consumption data into costs or emissions.

The causes may fill in the building caretaker, the alarms and their date and time should be imported from EMT's dynamat program automatically, whereas object description will be done by the project partners and the structural data may be fixed by Esbensen only. We see there is an importance to define writing rights. Viewing rights may be allowed for all partners. Deleting and altering data rights are associated with the writing rights.

The database consists of different data sets of different buildings. Each data set has a lot of data fields. Some data fields belong together; therefore a path through the data fields makes an easier orientation. The path also shows the links between the data fields too. This relation between the data fields and the rights for writing in these fields is shown on the following diagrams.

The authorization for the Esbensen database is connected with the login. Esbensen data base has an authorization for the dynamat program. Therefore the evaluation of all buildings is possible in the program. Maybe EMT/LEA allows the partners to enter their evaluation site of dynamat program directly too, if it is possible by internet. But it is not urgently necessary for this project.

EMT / dynamat needs the outside temperature as an own accounting scope like heating, electricity and water.

The EMT-program dynamat needs also some data fields (see deliverable 3) for each object so it can analyze the metering data. It is suggested to use the same information as written in the Esbensen data base in comparable data fields to get fewer complications.

An example for the Esbensen database-structure follows. See appendix 1, table 3 for the description of some data fields.

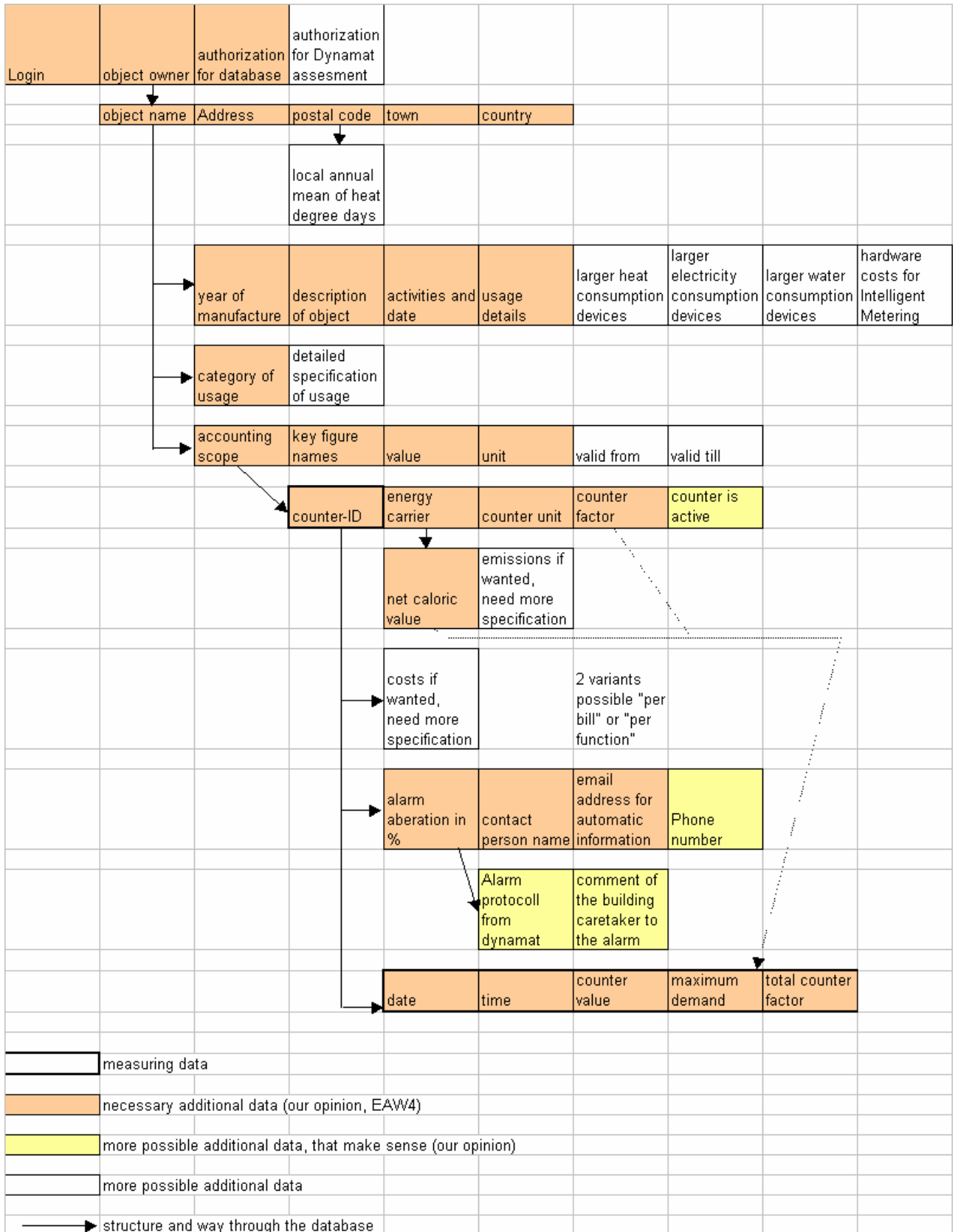

Example for the data structure of the database Esbensen may use for the intelligent metering project.

The automated data set of measuring data consists of counter-ID, date, time counter value, field 5 and field 6. Field 5 in the accounting scope electricity may show the maximum demand, which is of interest for billing reasons. But it is not necessary for the project and only an option.

Field 6 can be the total counter factor, which is the combination of net caloric value and counter factor. Both could be defined in the analyses program too.

A description of some important fields is included in the spreadsheet attached to this report.

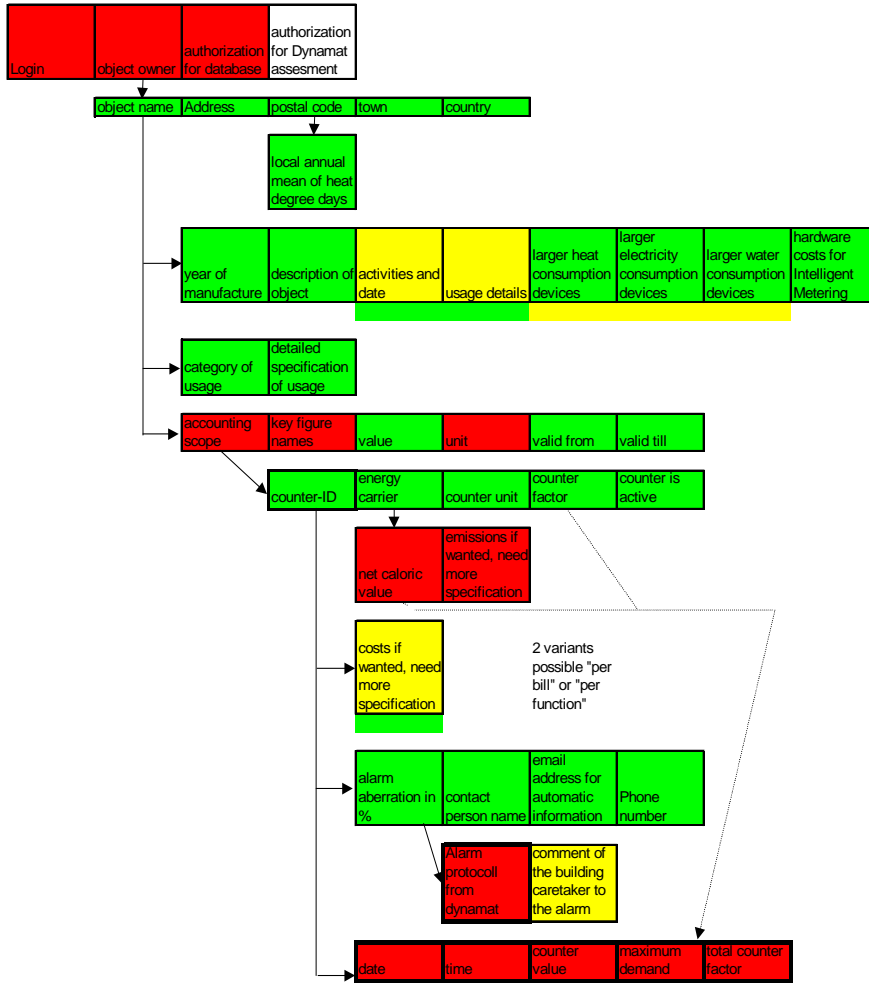

Who can overwrite, delete and fill in data ?

automatic data

All of this 3 user groups can view all data except the login - authorizati

administrator (Esbensen)

Building occupants (except caretaker) are not allowed to see the datab.

Example for the logical way through the database (and relation between the data fields). The groups of the writing right for the data fields are: red...administrator, green ...project partner, yellow...building caretaker. All 3 of them may view the data fields.

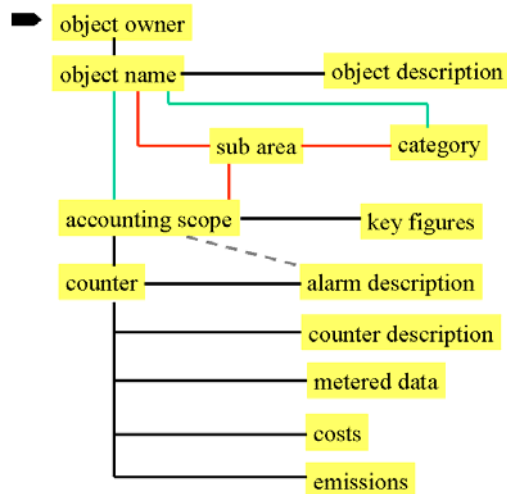

If we use sub areas, which means an area in a building with an own using category and with an own counter, the data structure has to be altered. The relation between the data fields in objects without sub areas is shown as a green line, if a sub area is chosen, the red line is valid. The alarm description and alarm data may be linked to the counter or the accounting scope.

The consumption may be connected with the costs or emissions. If we want to use the cost, we can choose two different ways.

a) **The function model:** the consumption is linked with mathematic formulas to the costs which will be paid in future.

Advantage: At the moment energy or water is consumed, we can evaluate the costs.

Disadvantage: It is very difficult to develop such a formula. Problems arise, if the prices changes very often in a year.

Example for such a formula:

A simplified bill may look like this

€0,141 per kWh consumption

€0,032 taxes per kWh

€16,44 per kW maximum load per year

€2,25 per month for metering

The first 2 components are linked with the consumed energy (variable parameter) whereas the next 2 components are linked with a time unit (may be year, month, hour,...), this is the „fixed parameter“. The formula will normally have both parameters in use.

b) **The billing model:** if a bill is coming, for the defined time the costs of the bill are inputted.

Advantage: It is easier and every change and aspect of the bill (e.g. discounts, short term price changes) can be considered.

Disadvantage: At the moment energy or water is consumed, it is not possible to evaluate the costs, we have to wait till the bill is delivered.

The link of consumption and emissions is easier. The kWh is defined with the net caloric value. For each air pollutant or greenhouse gas there is an own ratio of the amount of emissions per kWh. The most important greenhouse gas parameter is the cumulative one of CO₂-equivalent.

Key figures are interesting in a later phase of the project to compare and evaluate the effects of intelligent metering. The often used key figures are the following:

key figure name	heated area (gross)	volume (gross)	user (persons)	maximal load	using hours per day (or month)
unit	m ²	m ³	n	kW	hour
key figure energy	kWh/m ²	kWh/m ³	kWh/pers.	kWh/kW	kWh/hour
key figure water	m ³ water/m ²	m ³ water/m ³	m ³ water/person		m ³ water/hour

It is also often the net area and volume used, this vary in different countries. In general we can compare:
 heated area gross x 0,85 = about heated area net.
 Special objects have special key figures.

4.8 Heat degree correction:

The consumption of energy in the accounting scope heating depends on the climate, especially on the outside temperature. As we have alarm limits of aberration in consumption linked to target values, the dynamat program uses therefore a heat degree correction. In colder climates like in Austria, the outside temperature may be +5° Celsius or -25° C on a winter day. Therefore the function between outside temperature and consumption of heating energy is necessary – otherwise we get not wanted alarms caused by the climate.

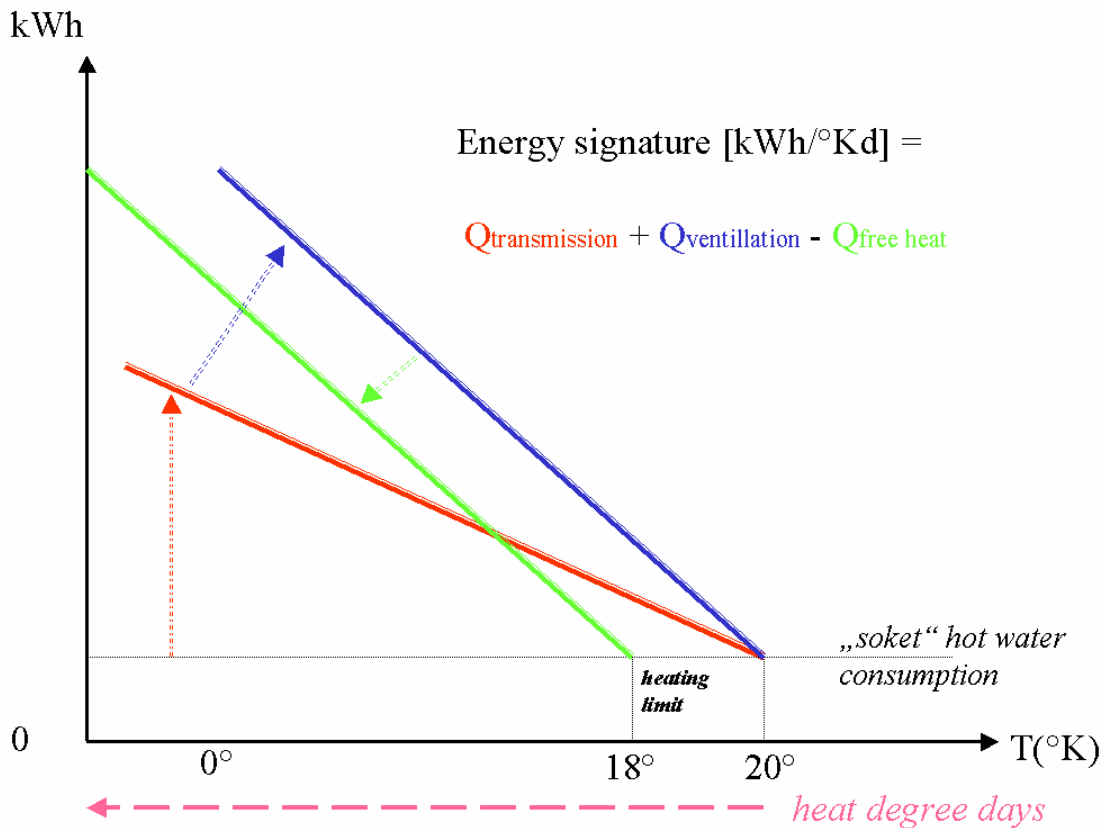

The ratio kWh/°Kd (Kelvin days) is different and typical for each object. This energy signature consists of the amount by transmission through walls, floor, roof and windows. Next there is a part of energy to add for the ventilation. The amount of free heat caused by persons and devices inside the room can be subtracted. So the heating limit to which we have to warm the room can be a little bit reduced. The picture

also shows a socket of energy consumption (a baseload) caused by the need for hot water which is not (directly) linked to the outside temperature for heating the rooms.

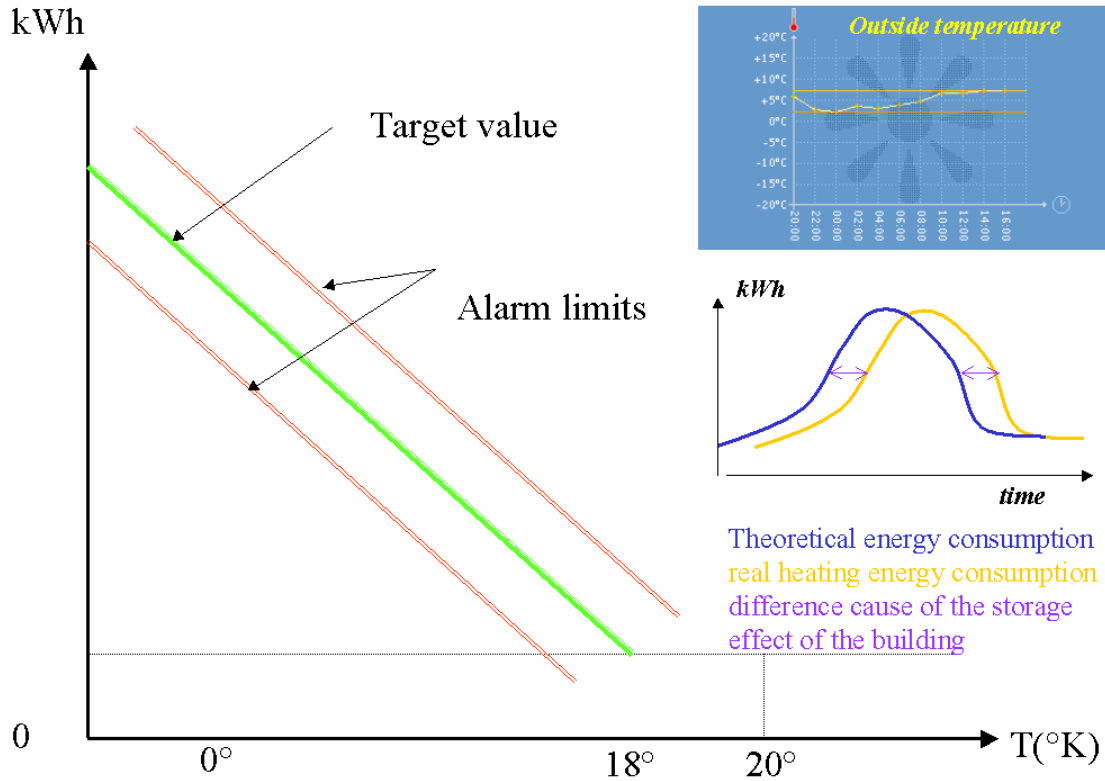

The outside temperature and the amount of heating have different minima/maxima, often a night reduction of the temperature is done in objects. The buildings have a temperature storage effect, therefore the kWh/Kd –value does not lie on the line. First there is more energy needed than the outside temperature makes us thinking. The walls are heated and reduce the energy need later on. Therefore the alarm limits could be reached although without a reason we could alter into a better state. Some experts think that a heat degree correction is not suitable for half an hour values or hour values. They say that the day is the minimum interval for a heat degree correction. Maybe we will have to enlarge the aberration interval for alarm, reduce the sensitivity (e.g. from hourly to 1 day or 1 week deviation) or need 2 or 3 alarm exceeding half hour values to activate the alarm. We will see the applicability in this project.

EMT does their heat degree correction by using a floating interval of correction? There are two methods of degree day correction within the DYNAMAT software.

The first is to use published monthly degree day totals for the location, and there is a specific table in the DYNAMAT database for this. DYNAMAT then performs regression analysis of energy consumption vs. degree days by calendar month, and calculates a best fit line ($y=mx+c$) and hence an expected level of consumption given a number of degree days. 20 year average degree days can also be entered, and the consumption "normalized" to what would have been the case had 20 year average weather occurred. The formula used is:-

$$C_w = (C_a - c) * DD_{20} + c$$

where

C_w = weather corrected consumption
 C_a = actual consumption
 c = base load calculated from regression analysis
 DD_{20} = 20 year average degree days
 DD = actual degree days

The calculation can only be performed to a time resolution of one month, and only to one or two temperature baselines, because of the limitations of the data supplied.

The second and preferable method is to have an outside air temperature sensor included as part of the automatic meter reading system. DYNAMAT then stores the temperature readings in the database along with energy meter readings and calculates degree days "on the fly" whenever requested. Thus degree days can be calculated to any desired base line, and regression analysis performed to any desired time resolution. The degree days can also be truncated to the days when the building is in use.

Dynamat would record temperature every hour, but always perform the degree day correction calculation on a rolling 24 hour or longer window of time, long enough to smooth out any effects of storage mass, daily operation times of the heating etc. Often 1 week is suggested to choose for the window of time to be best.

The collected data may help us to find out the best interval to use for a heat degree correction and alarming system. The kWh/Kd – ratio can give us information about the different objects too. Therefore it would be interesting to evaluate this ratio. The following picture shows examples of possible curves and known interpretations.

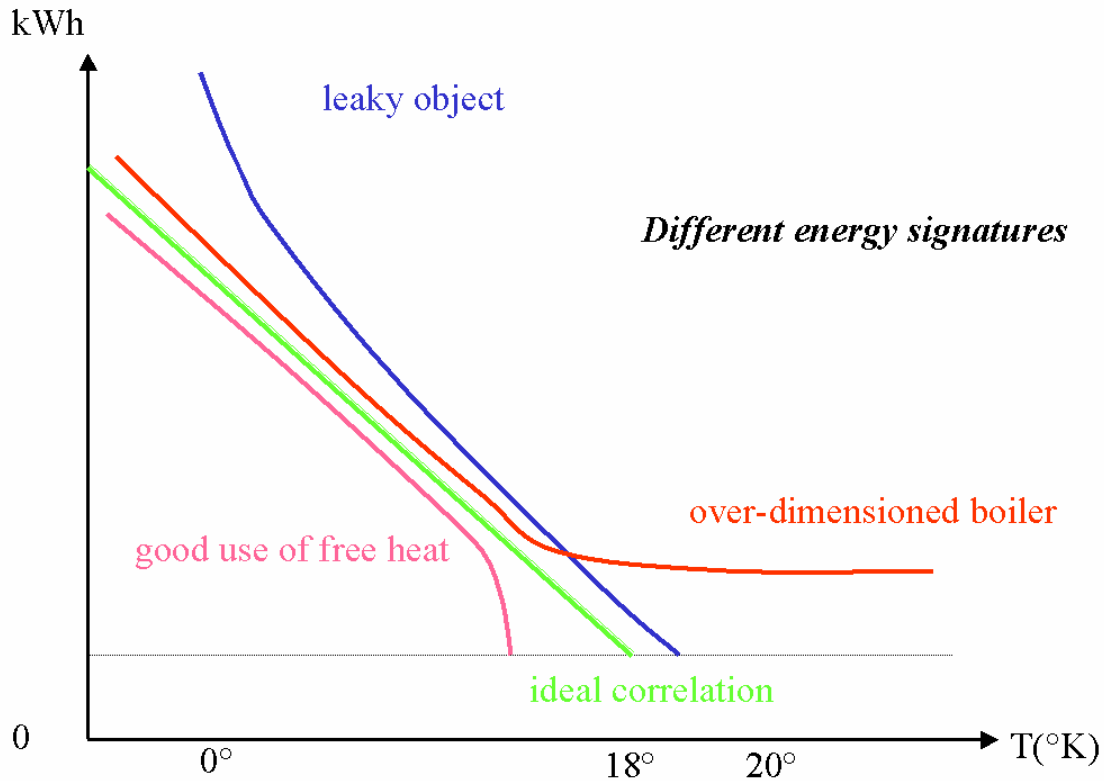

5. Conclusions

- The sectors of the building, the uses and the according counters should be analysed very precisely.
- On the market different counters are offered. The counters should at least be able to pass on impulses.
- Minimum-counter equipment of a building:
 - counter for heating
 - counter for electric current
 - counter for water
 - outside-temperature sensor (treated as counter)
- Esbensen has to establish the database.
- All the project partners need to know the exact internet address from Esbensen to send the metering data.
- Esbensen or the project partners have to fill in the additional data manually.
- Leicester energy agency and Esbensen have to work together for the automatic procedures between their servers connecting Esbensen database to LEA's dynamat program.
- Esbensen has to establish a time table for automated sending procedures of the different partners to and from their server to reduce traffic peaks.
- The dynamat and Esbensen database should use the content in comparable data fields (e.g. building name, number of occupants, building year,...). We have to use two databases because of the structure of the project, which can be seen as a disadvantage.

Disclaimer

The sole responsibility for this document lies with the authors. It does not represent the opinion of the Community. The European Commission is not responsible for any use that may be made of the information contained therein.